

BENaBEC

ARCHITECTURAL CUSTOM  
PRECAST PRODUCTS

# Product Catalogue



Ontarios leader  
in architectural  
precast and cast  
stone

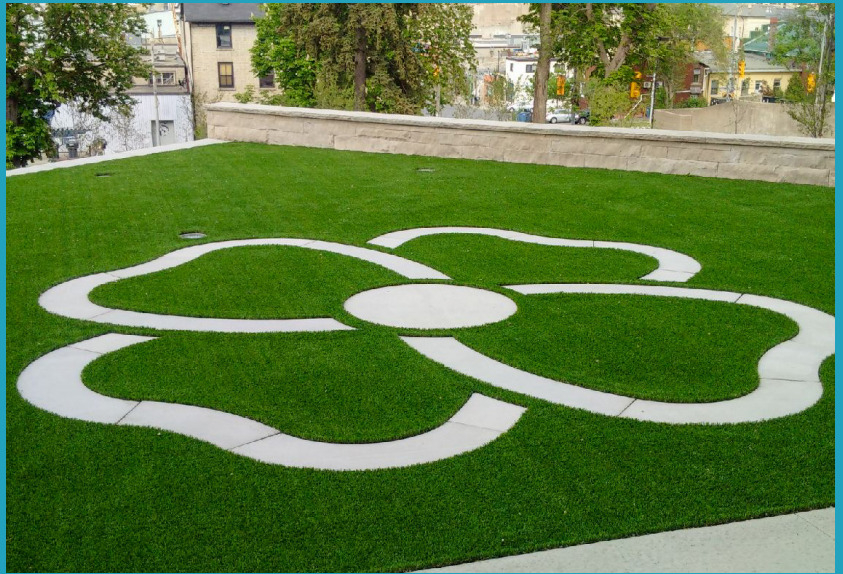

## Introduction

### ABOUT OUR COMPANY

Benabec Architectural Products Ltd is a family owned full service precast shop that has been based out of southern Ontario for over 30 years

Specializing in Architectural Precast for residential, commercial, and restoration projects, Benabec Architectural Products guarantees the highest quality finishes, most accurate dimensions, and the expertise to complete your project on time and within budget.

Our industry leading mould making allows us to create the most complicated shapes, to the highest possible standards

# Contents

Introduction 02

Sills 04

Pier Caps 07

Banding 10

Foils/Inserts 12

Keystones 13

Surrounds 14

Arches 15

Precast Panels 16

Extras 17

Process 18

Technological Specifications 19

# Sills

STANDOUT FEATURES AT AN AFFORDABLE PRICEPOINT

With our wide range of available sill profiles, we are sure to have an aesthetic that meets your needs. Sills are available in standard lengths (48",60",72") or can be made in custom sizes specifically for your project. Contact our sales rep for additional shapes, sizes, or colours

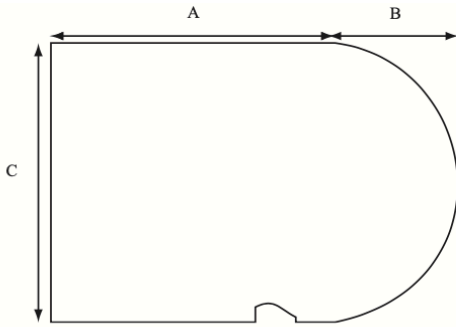

Item #	A	B	C
SI 001-3	5	1 1/2	3 5/8
SI 001-4	5	2	4 5/8
SI 001-5	5	2 13/32	5 5/8
SI 001-7	5	3 1/4	7 5/8

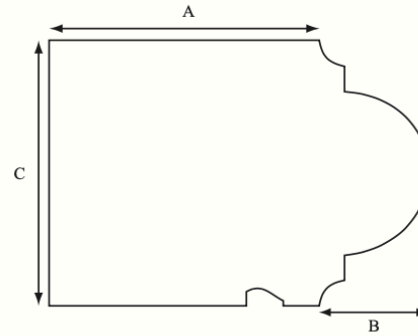

Item #	A	B	C
SI 002-3	5	1 1/2	3 5/8
SI 002-4	5	1 7/8	4 5/8
SI 002-5	5	2 1/4	5 5/8
SI 002-7	5	3	7 5/8

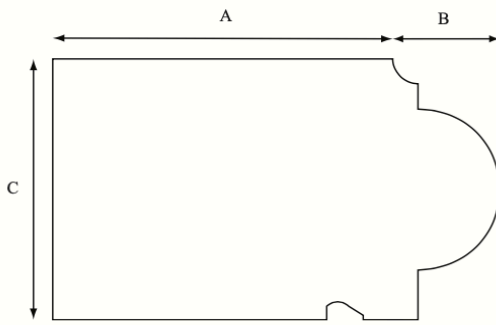

Item #	A	B	C
SI 003-3	5	1 1/2	3 5/8
SI 003-4	5	1 7/8	4 5/8
SI 003-5	5	2 1/4	5 5/8
SI 003-7	5	3	7 5/8

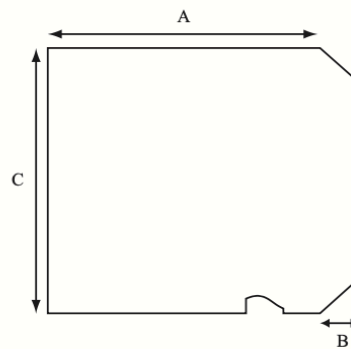

Item #	A	B	C
SI 004-3	5	1/2	3 5/8
SI 004-4	5	11/16	4 5/8
SI 004-5	5	13/16	5 5/8
SI 004-7	5	1 1/8	7 5/8

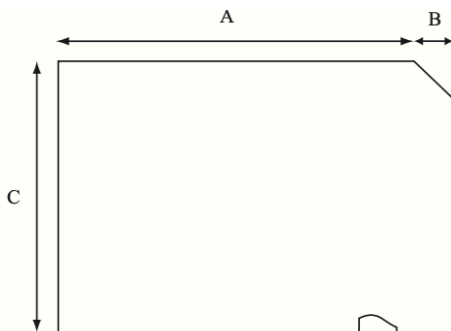

Item #	A	B	C
SI 005-3	5	1/2	3 5/8
SI 005-4	5	11/16	4 5/8
SI 005-5	5	13/16	5 5/8
SI 005-7	5	1 1/8	7 5/8

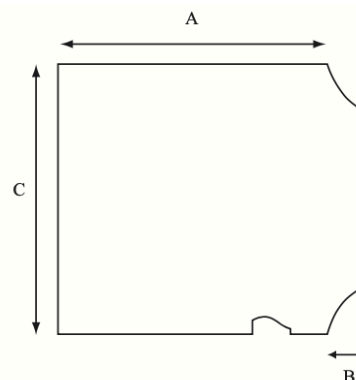

Item #	A	B	C
SI 006-3	5	1/2	3 5/8
SI 006-4	5	11/16	4 5/8
SI 006-5	5	13/16	5 5/8
SI 006-7	5	1 1/8	7 5/8

**BENABEC FOR RESTORATION AND REPAIR**

Need to match a profile on an existing project? Our design team will make an exact replica for any size of job.

**INDUSTRY LEADERS IN MOULDMAKING**

Benabec is Proud to offer the highest quality finish and the most intricate profiles. All sill profiles are available with return corners and finished ends by request.

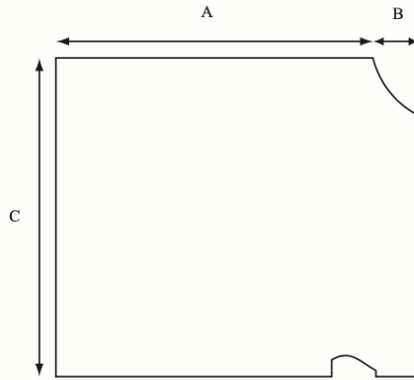

Item #	A	B	C
SI 007-3	5	1/2	3 5/8
SI 007-4	5	11/16	4 5/8
SI 007-5	5	13/16	5 5/8
SI 007-7	5	1 1/8	7 5/8

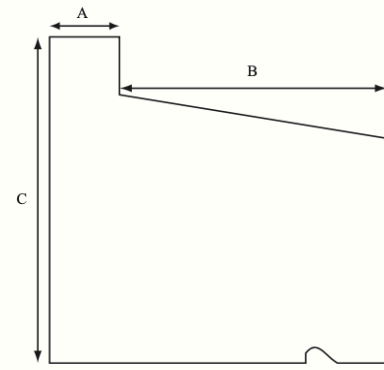

Item #	A	B	C	D
SI 008-3	1	4 1/8	5	3 5/8

D - width of brick lug  
Other sizes available

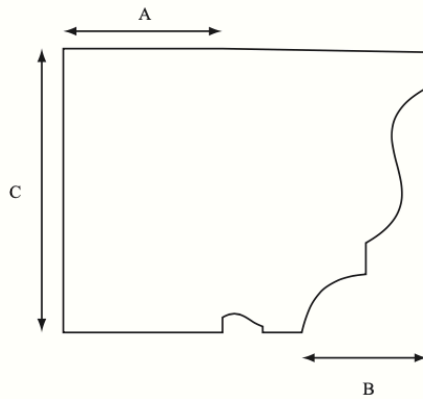

Item #	A	B	C
SI 009-3	5	1 1/2	3 5/8
SI 009-4	5	2	4 5/8
SI 009-5	5	2 7/16	5 5/8
SI 009-7	5	3 5/16	7 5/8

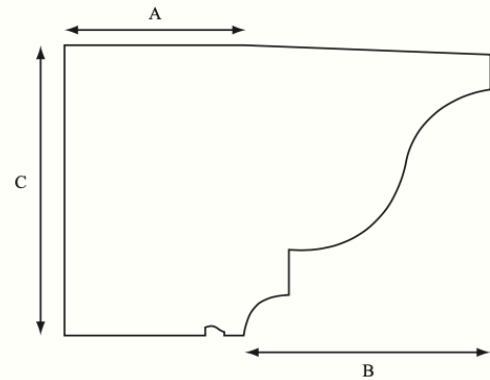

Item #	A	B	C
SI 010-3	5	3	3 5/8
SI 010-4	5	3 7/8	4 5/8
SI 010-5	5	4 3/4	5 5/8
SI 010-7	5	6 7/16	7 5/8

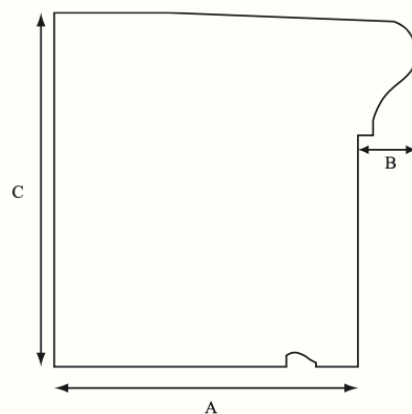

Item #	A	B	C
SI 011	5 3/16	1	6 1/8

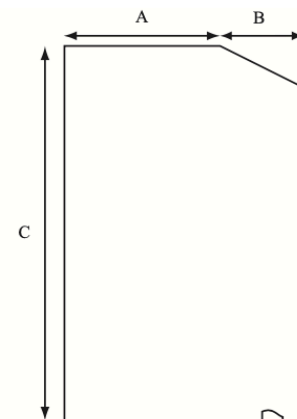

Item #	A	B	C
SI 012-4	3 5/8	2	4 1/4

AVAILABLE SLOPE

All sill profiles available with a premade slope upon request

# Sills

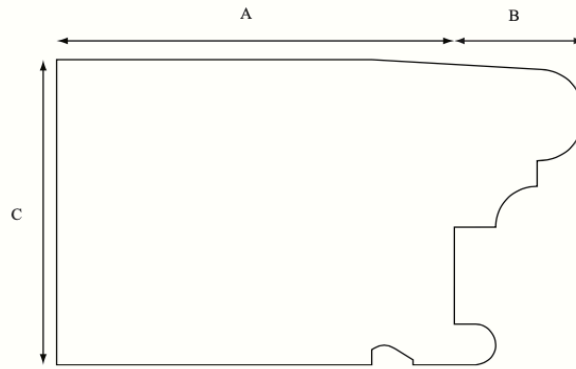
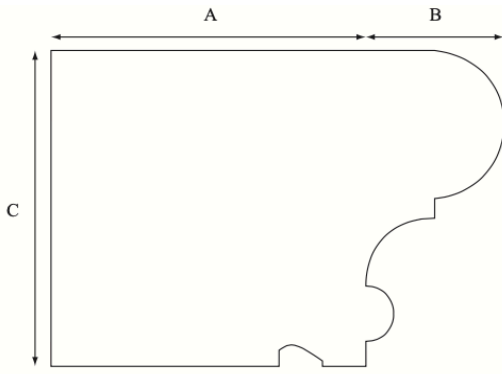

Item #	A	B	C
SI 013-3	5	1 1/16	3 5/8
SI 013-4	5	2	4 5/8
SI 013-5	5	2 7/16	5 7/8
SI 013-7	5	3 5/16	7 5/8

Item #	A	B	C
SI 014-3	5	1 1/2	3 5/8
SI 014-4	5	2	4 5/8
SI 014-5	5	2 1/4	5 5/8
SI 014-7	5	3 3/16	7 5/8

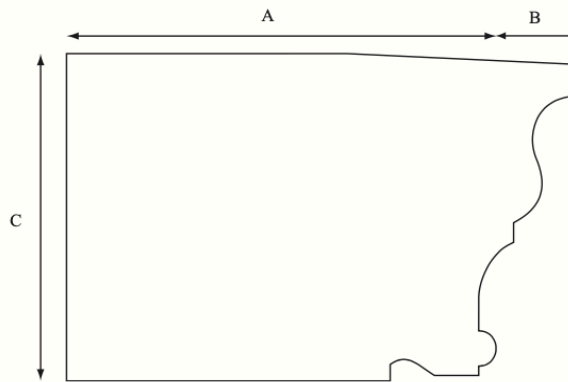
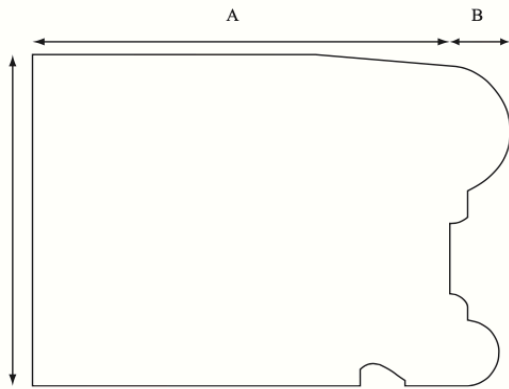

Item #	A	B	C
SI 015-3	5	5/8	3 5/8
SI 015-4	5	7/8	4 5/8
SI 015-5	5	1	5 5/8
SI 015-7	5	1 3/8	7 5/8

Item #	A	B	C
SI 016-3	5	1	3 5/8
SI 016-4	5	1 3/8	4 5/8
SI 016-5	5	1 11/16	5 5/8
SI 016-7	5	2 5/16	7 5/8



A custom made sill profile for a restoration project in Paris, Ontario. All sill profiles available with finished ends and return corners

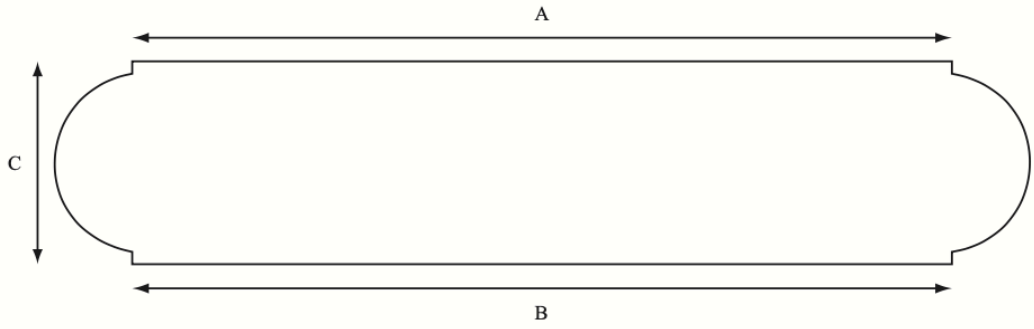

Item #	A	B	C
PCF 001-16	16	16	4
PCF 001-18	18	18	4
PCF 001-20	20	20	4
PCF 001-22	22	22	4

Other sizes available

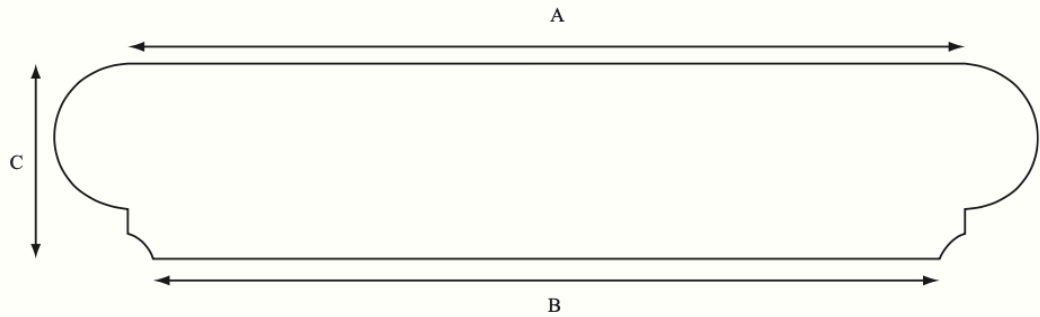

Item #	A	B	C
PCF 003-16	17	16	4
PCF 003-18	19	18	4
PCF 003-20	21	20	4
PCF 003-22	23	22	4
PCF 003-24	25	24	4

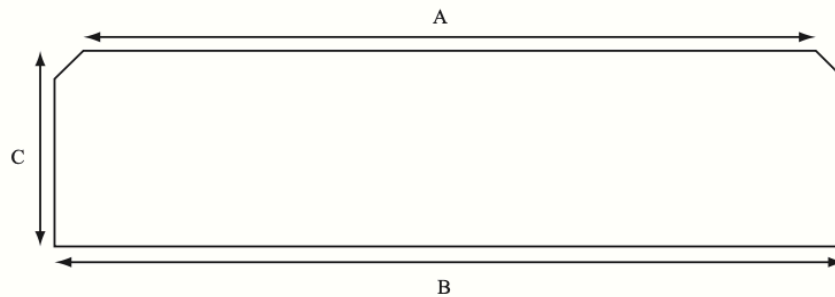

Item #	A	B	C
PCF 005-16	14 13/16	16	4
PCF 005-18	16 13/16	18	4
PCF 005-20	18 13/16	20	4
PCF 005-22	20 13/16	22	4
PCF 005-24	22 13/16	24	4

## AVAILABLE PEAK

All Pier Cap profiles available with a pre-made Center peak upon request

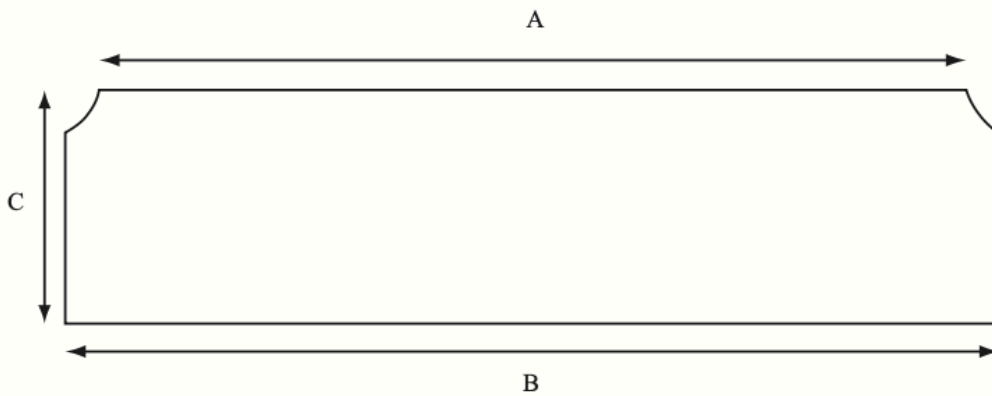

Item #	A	B	C
PCF 007-16	14 13/16	16	4
PCF 007-18	16 13/16	18	4
PCF 007-20	18 13/16	20	4
PCF 007-22	20 13/16	22	4
PCF 007-24	22 13/16	24	4

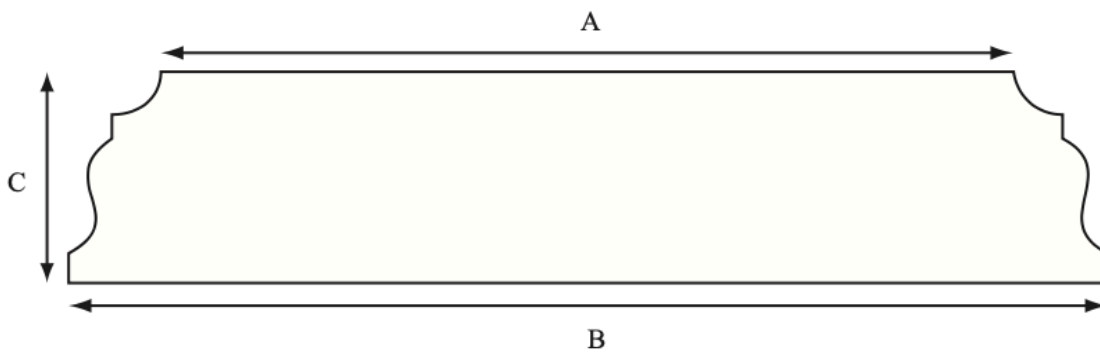

Item #	A	B	C
PCF 009-16	16	19 1/2	4
PCF 009-18	18	21 1/2	4
PCF 009-20	20	23 1/2	4
PCF 009-22	22	25 1/2	4
PCF 009-24	24	27 1/2	4



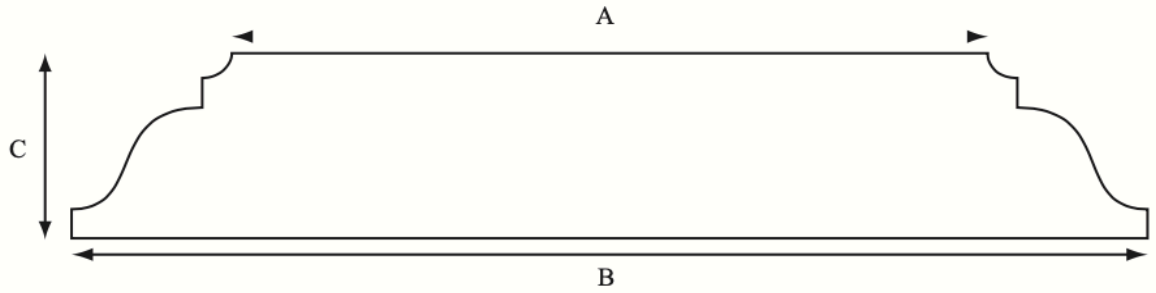

Item #	A	B	C
PCF 010-16	16	22 3/4	4
PCF 010-18	18	24 3/4	4
PCF 010-20	20	26 3/4	4
PCF 010-22	22	28 3/4	4
PCF 010-24	24	30 3/4	4

Other sizes available

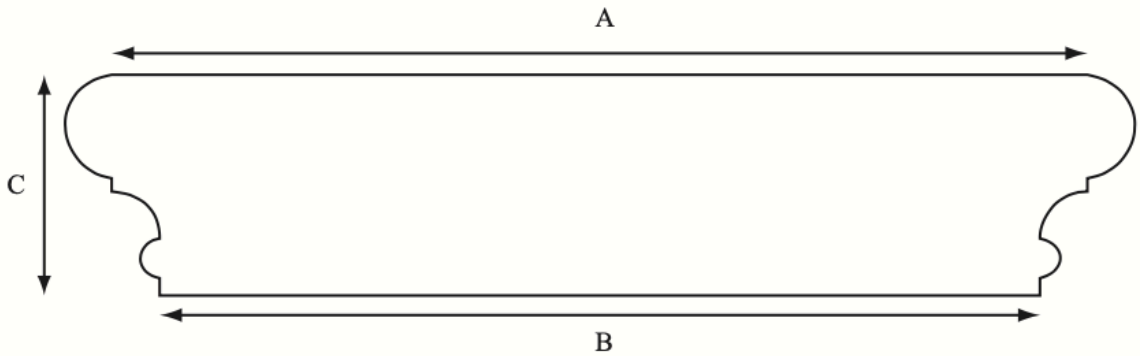

Item #	A	B	C
PCF 013-16	17 3/4	16	4
PCF 013-18	19 3/4	18	4
PCF 013-20	21 3/4	20	4
PCF 013-22	23 3/4	22	4
PCF 013-24	25 3/4	24	4

Other sizes available

# Banding

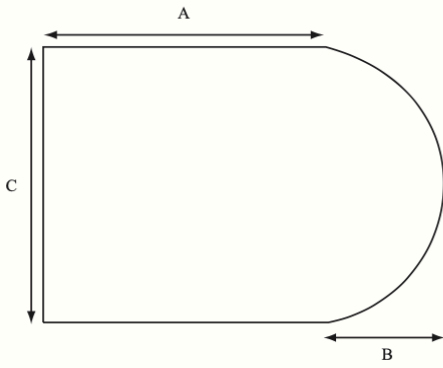

Item #	A	B	C
BG 001-3	3 5/8	1 1/2	3 5/8
BG 001-4	3 5/8	2	4 5/8
BG 001-5	3 5/8	2 13/32	5 5/8
BG 001-7	3 5/8	3 1/4	7 5/8

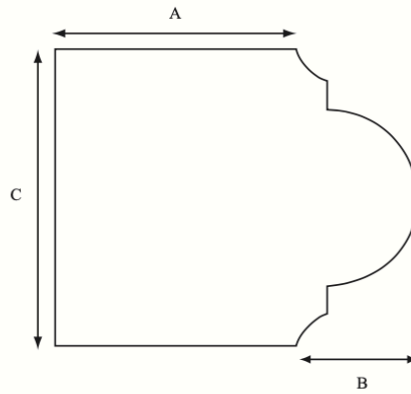

Item #	A	B	C
BG 002-3	3 5/8	1 3/8	3 5/8
BG 002-4	3 5/8	1 7/8	4 5/8
BG 002-5	3 5/8	2 1/4	5 5/8
BG 002-7	3 5/8	3	7 5/8

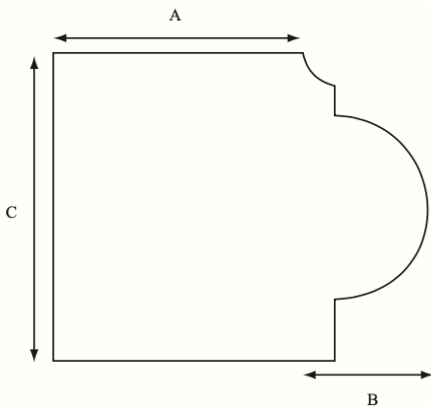

Item #	A	B	C
BG 003-3	3 5/8	1 3/8	3 5/8
BG 003-4	3 5/8	1 7/8	4 5/8
BG 003-5	3 5/8	2 1/4	5 5/8
BG 003-7	3 5/8	3	7 5/8

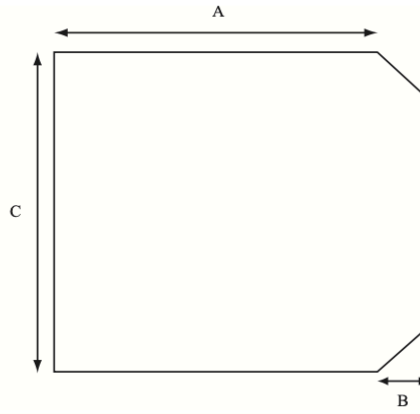

Item #	A	B	C
BG 004-3	3 5/8	1/2	3 5/8
BG 004-4	3 5/8	11/16	4 5/8
BG 004-5	3 5/8	13/16	5 5/8
BG 004-7	3 5/8	1	7 5/8

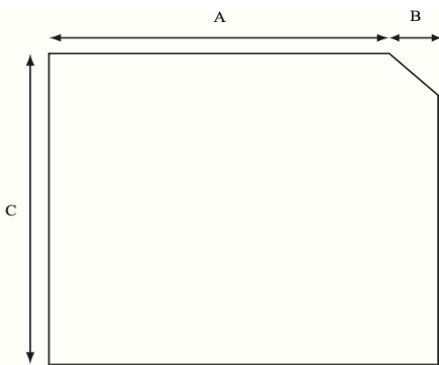

Item #	A	B	C
BG 005-3	3 5/8	1/2	3 5/8
BG 005-4	3 5/8	11/16	4 5/8
BG 005-5	3 5/8	13/16	5 5/8
BG 005-7	3 5/8	1	7 5/8

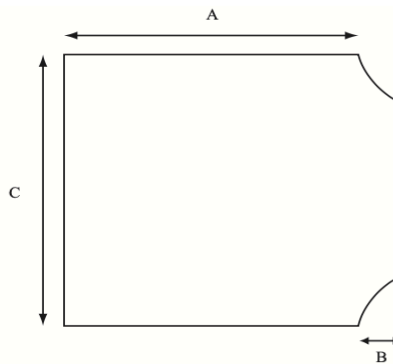

Item #	A	B	C
BG 006-3	3 5/8	1/2	3 5/8
BG 006-4	3 5/8	3/4	4 5/8
BG 006-5	3 5/8	3/4	5 5/8
BG 006-7	3 5/8	1	7 5/8

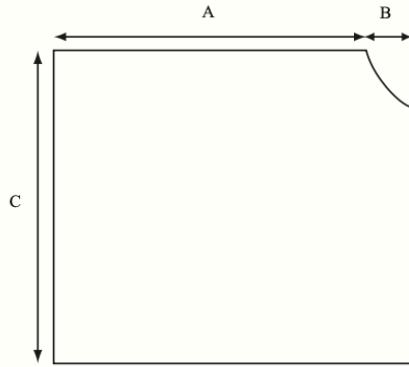

Item #	A	B	C
BG 007-3	3 5/8	1/2	3 5/8
BG 007-4	3 5/8	3/4	4 5/8
BG 007-5	3 5/8	3/4	5 5/8
BG 007-7	3 5/8	3/4	7 7/8

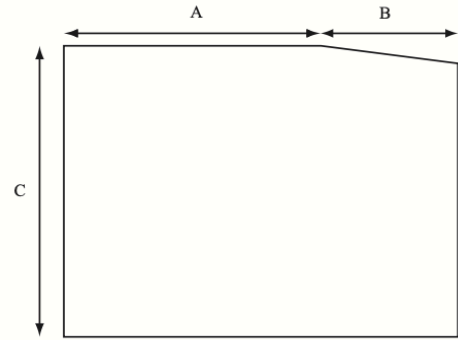

Item #	A	B	C
BG 012-4	3 5/8	2	4 1/4
BG 012-9	3 5/8	2	9

Other Sizes Available

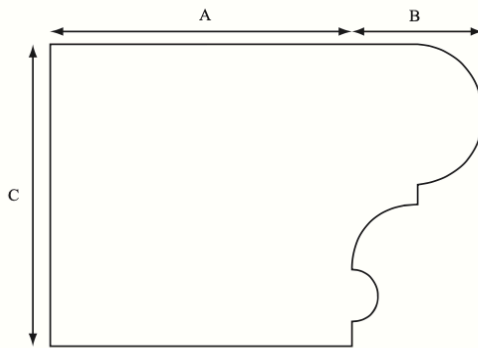

Item #	A	B	C
BG 013-3	3 5/8	1 1/2	3 5/8
BG 013-4	3 5/8	2	4 5/8
BG 013-5	3 5/8	2 7/16	5 5/8
BG 013-7	3 5/8	3 5/16	7 5/8

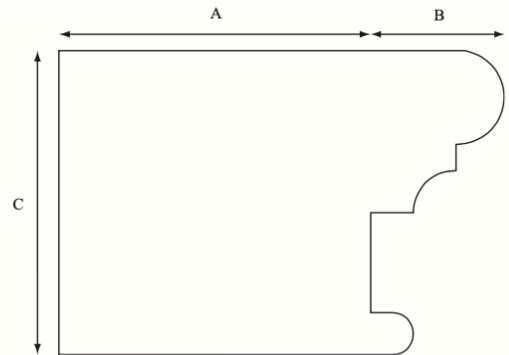

Item #	A	B	C
BG 014-3	3 5/8	1 1/2	3 5/8
BG 014-4	3 5/8	2	4 5/8
BG 014-5	3 5/8	2 7/16	5 5/8
BG 014-7	3 5/8	3 1/4	7 5/8

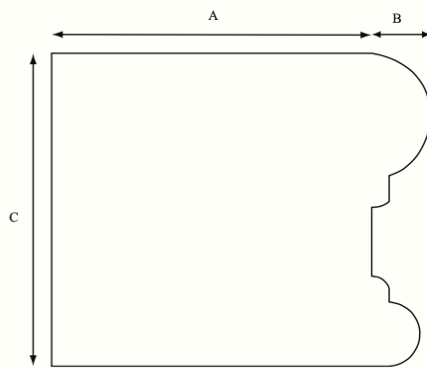

Item #	A	B	C
BG 015-3	3 5/8	5/8	3 5/8
BG 015-4	3 5/8	7/8	4 5/8
BG 015-5	3 5/8	1	5 5/8
BG 015-7	3 5/8	1 3/8	7 5/8

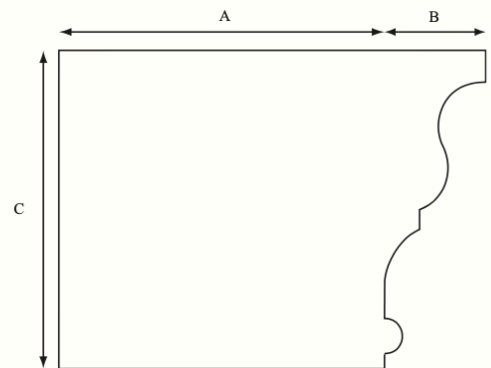

Item #	A	B	C
BG 016-3	3 5/8	1 1/8	3 5/8
BG 016-4	3 5/8	1 7/16	4 5/8
BG 016-5	3 5/8	1 3/4	5 5/8
BG 016-7	3 5/8	2 3/8	7 5/8

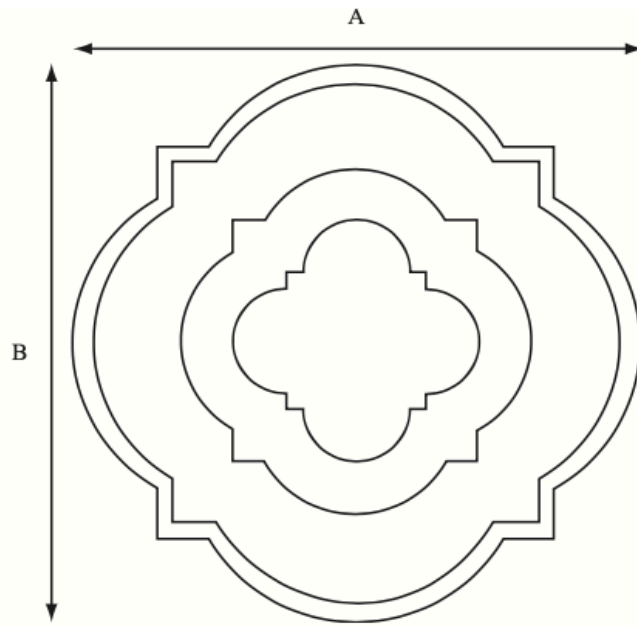

Item #	A	B	Depth	Profile
FO 001-2	26	26	3 5/8	1

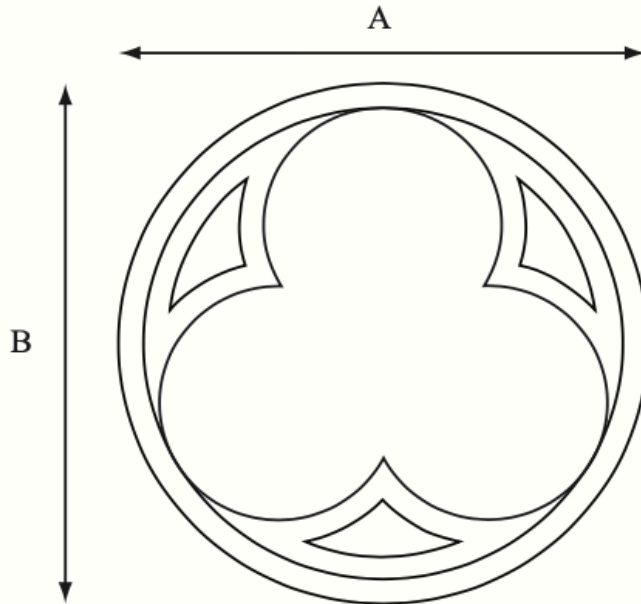

Item #	A	B	Depth	Profile
FO 002-3-2	24	24	3 5/8	1

Others sizes available.

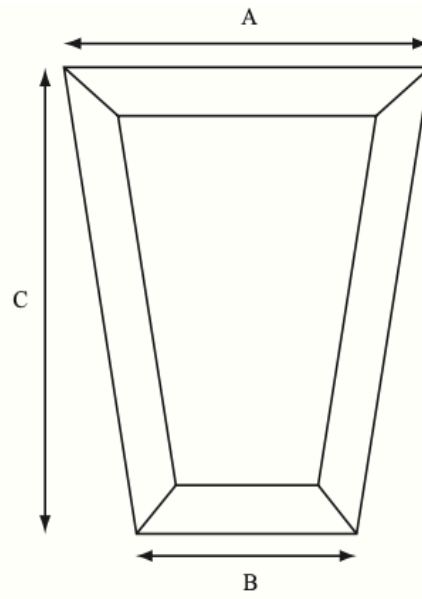

<b>Item #</b>	<b>A</b>	<b>B</b>	<b>C</b>	<b>Depth</b>	<b>Profile</b>
KS 001-05	5	3	6	3 5/8	3/4
KS 001-12	2	5 1/4	13 1/4	3 5/8	7/8

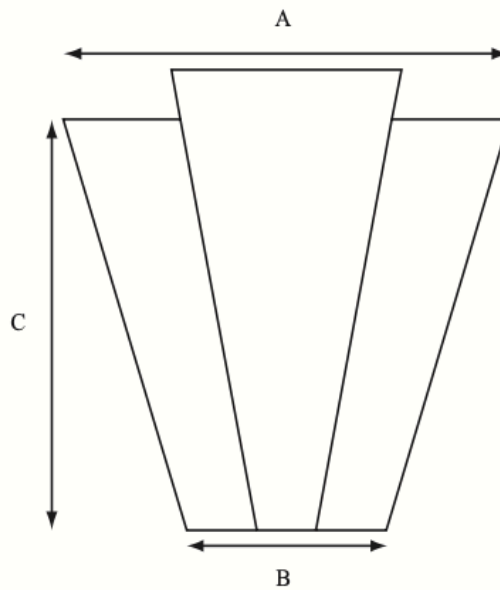

<b>Item #</b>	<b>A</b>	<b>B</b>	<b>C</b>	<b>Depth</b>	<b>Profile</b>
KS 002	9 1/2	4 1/4	9 1/4	3 5/8	1 5/8

# Surrounds

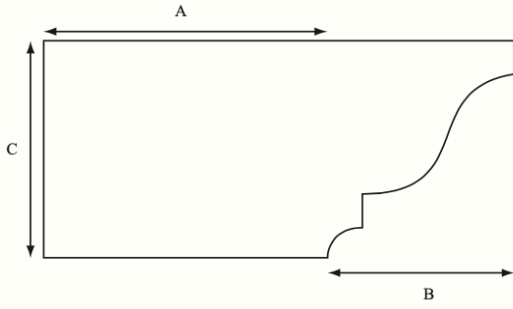

Item #	A	B	C
SU 010-3	3 5/8	3	3 5/8
SU 010-4	3 5/8	3 7/8	4 5/8
SU 010-5	3 5/8	4 3/4	5 5/8
SU 010-7	3 5/8	6 7/16	7 5/8

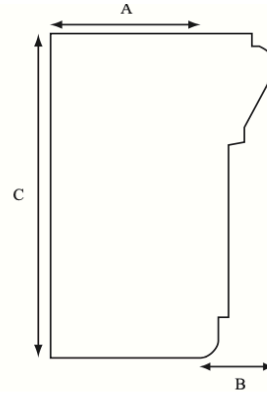

Item #	A	B	C
SU 011	3 5/8	1 13/16	8

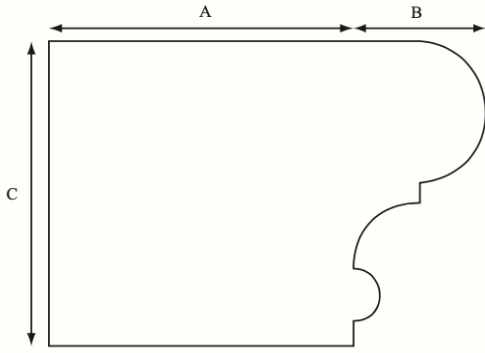

Item #	A	B	C
SU 013-3	3 5/8	1 1/2	3 5/8
SU 013-4	3 5/8	2	4 5/8
SU 013-5	3 5/8	2 7/16	5 5/8
SU 013-7	3 5/8	3 5/16	7 5/8

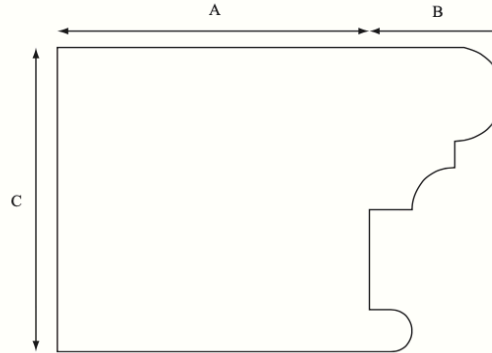

Item #	A	B	C
SU 014-3	3 5/8	1 1/2	3 5/8
SU 014-4	3 5/8	2	4 5/8
SU 014-5	3 5/8	2 7/16	5 5/8
SU 014-7	3 5/8	3 1/4	7 5/8

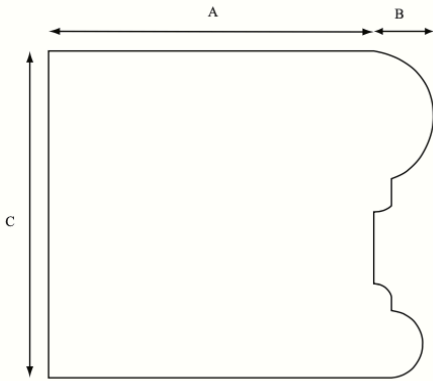

Item #	A	B	C
SU 015-3	3 5/8	5/8	3 5/8
SU 015-4	3 5/8	7/8	4 5/8
SU 015-5	3 5/8	1	5 5/8
SU 015-7	3 5/8	1 3/8	7 5/8

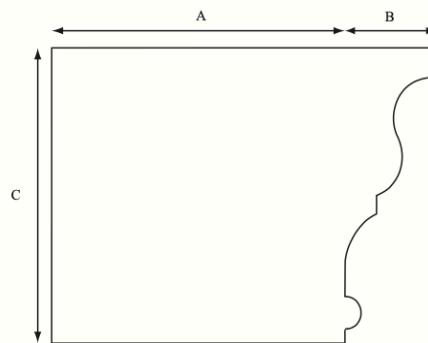

Item #	A	B	C
SU 016-3	3 5/8	1 1/8	3 5/8
SU 016-4	3 5/8	1 7/16	4 5/8
SU 016-5	3 5/8	1 3/4	5 5/8
SU 016-7	3 5/8	2 3/8	7 5/8
SU 016-10	3 5/8	3	10

Benabec arches are custom made to fit your projects needs. All features are drawn by our experienced team of designers to allow for the tightest possible tolerances. Contact our sales rep for additional shapes, sizes, or colours



#### STANDOUT QUALITY

We customize each mould to make your building exterior thrive. Each piece being made to the highest quality in our shop saves your installaton team time on site and keeps your project on schedule.

#### DESIGNED FOR YOUR PROJECT

Benabec arches, jambs and headers are designed to your specifications. Complex shapes and profiles can be designed in as many or as few pieces as needed by your project.

(Right) A Benabec drawing for a restoration project. complex pieces and arches are removed and remade in our industry leading facilities

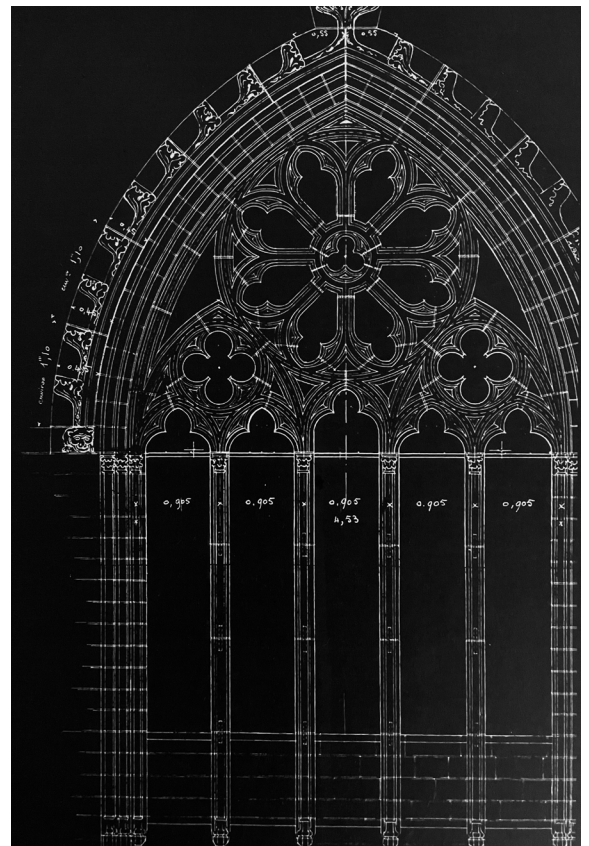

# Precast Panels

Benabec Precast Panels are custom made for your project to create the most seamless finished product possible. We will work with your masons to analyze site conditions, layout, and installation techniques, ensuring that your building projects the exemplary quality craftsmanship you are trying to achieve. Contact our sales rep for additional shapes, sizes, or colours



Our Pannels are designed and made to your installation crews requirements. All pieces can be made with return corners and with any inlay requested.

(Left) A residential procect featuring Benabec Sills (SI-05) Benabec 8x16 Chamfered panels, Benabec cornice (SU-16), Benabec Keystones (KS-05) Surrounds (SU-001) and more!



# Additional services

All additional services are available in house, contact our sales representative for more information

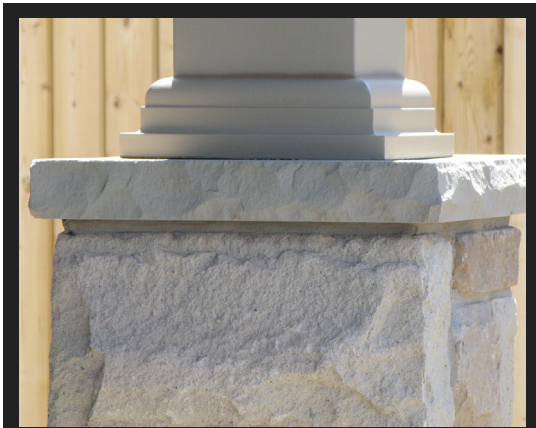

Rock Face



Signs



Chimney Caps

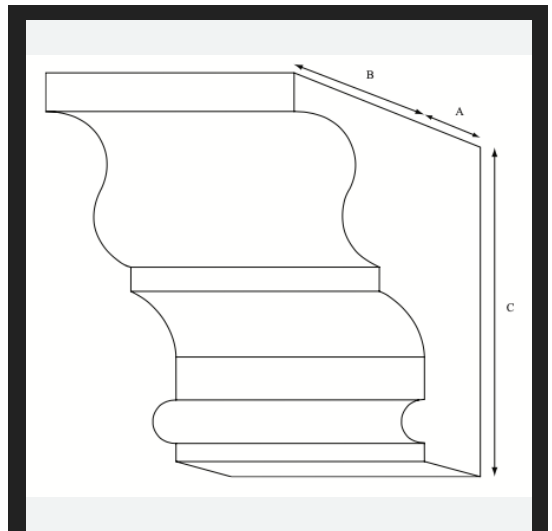

Shop Drawings

# Our Process

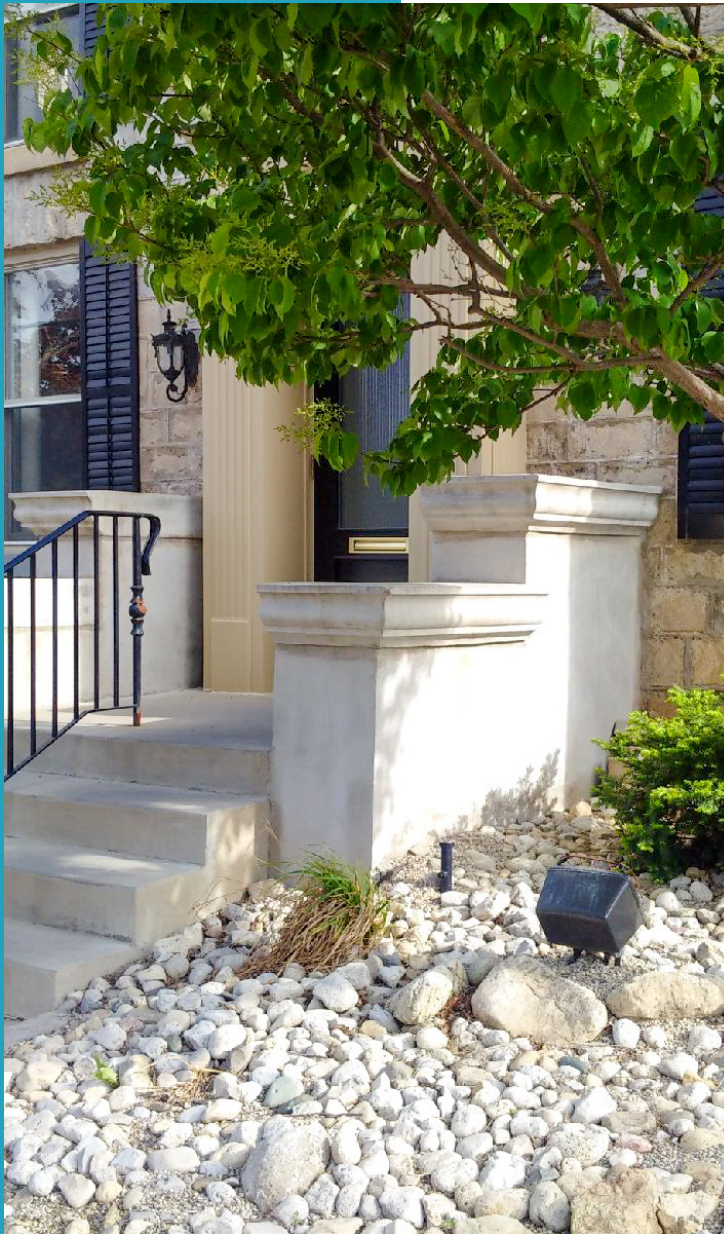

Complex shapes  
Consistent finishes  
Timeless Design

## Precast by Design

KEEPING YOUR PROJECT ON SCHEDULE AND WITHIN BUDGET

Our Precast products use industry leading concrete technology and are twice hand sanded to ensure the most consistent finish.

All of our molds are CNC cut to create a product with no warping and made to the exact sizes your project requires.

Our in house design team will collaborate with your project managers to create shop drawings, consult on installation techniques, and streamline the layout process.

## Materials of Construction

1. Portland Cement: ASTM C 150 Type 10 ; Colour to be white or gray as required to achieve proper colour match as determined by customer specifications.
2. Aggregate: ASTM C 33 ; Coarse and fine aggregate may be white or darker in colour as required to achieve proper colour match as determined by customer specifications.
3. Pigments: ASTM C 979; Inorganic, non-fading, resistant to lime and other alkalis. Pigments not to exceed 10% of cement weight.
4. Water: Potable, free from foreign materials in amounts harmful to concrete or steel within the casting.
5. Air Entrainment Admixture: ASTM C 260
6. Reinforcement: Reinforcing bars as necessary for safe handling, setting and structural stress and where specified by customer will be epoxy coated. The size of the reinforcing shall be a minimum area of steel equal to one quarter of one percent of the cross section area.
7. Surface Colour: Match sample on file in architect's office when applicable.
8. Surface Finish: Units shall exhibit a texture approximately equal to the approved sample when viewed under a direct daylight illumination at a distance of 10 ft. (3m) distance.  
All surfaces intended to be exposed to view, shall have a contiguous texture as specified by customer or as submitted for approval to architect. There shall be no voids in excess of 1/32 in. and not be obvious from a distance of not less than 5 ft. Minor chipping resulting from shipping, shall not be grounds for rejection. Minor chips shall not be obvious from a distance of 20ft. in direct daylight illumination.  
The occurrence of crazing or efflorescence shall not be cause for rejection.
9. Curing: Cure elements in a moist area of as close to 95% relative humidity as reasonable for approximately 12 hours at a minimum of 70 F after casting. Additional yard curing of 7 days at 50 F or 5 days at 70 F .
10. Manufacturing Tolerances: Cross section dimensions, overall length of units or warp, bow and twist of units shall not deviate by more than +/- 1/8 in. from approved dimensions.
11. Examination: It is the responsibility of the customer, upon receipt of units to examine them for approved finish and fit. Do not set unacceptable units. Once defective or unacceptable units have been set it is the sole responsibility of the contractor/customer to cover all replacement costs to be incurred.



CONTACT OUR SALES TEAM AT  
519-624-0766  
BENABEC.PRECAST@GMAIL.COM  
[WWW.BENABECPRECAST.COM](http://WWW.BENABECPRECAST.COM)